

Employing Rapid Prototyping in a First-Year Engineering Graphics Course

Wayne M. Johnson¹, Cameron W. Coates², Patrick Hager³, and Nyrell Stevens⁴

Abstract – Over the past several years, rapid prototyping has played a greater role in engineering graphics education. This is evident by the inclusion of discussions on rapid prototyping technology in most of the recent engineering graphics textbooks, and the use of rapid prototyping in the engineering graphics curricula at various colleges and universities. A major barrier in the adoption of rapid prototyping at smaller educational institutions continues to be the relatively high cost of rapid prototyping machines. This paper presents our efforts to integrate rapid prototyping into our freshman engineering graphics course at Armstrong Atlantic State University. We will discuss our experiences in the acquisition, development, and implementation of the rapid prototyping course materials. We will also present qualitative results of our student’s perceptions of the rapid prototyping course modules. This work will be useful to other two-year engineering programs seeking to implement rapid prototyping into their engineering graphics or introduction to engineering courses.

Keywords: rapid prototyping, engineering graphics, CAD, model

INTRODUCTION

Access to physical models during the design process can be very helpful to engineers and students as they assess the functionality of individual parts and integration with other parts in an assembly. Rapid prototyping encompasses various techniques that can be used to create physical models based on 3D computer-aided design (CAD) models. Many corporations with major engineering design needs have quickly adopted rapid prototyping (RP) to address this need. In turn, academia has responded to this change with the inclusion of RP topics in recent engineering graphics textbooks [1-3], and the use of RP in the engineering graphics curricula at various colleges and universities [4-6].

Rapid prototyping begins with the conversion of a 3D CAD model into an STL (stereolithography) file. This process discretizes the model’s surface into small triangles. The model can then be “sliced” into cross-sections or layers which can be sequentially built up with a rapid prototyping machine. Some of the more common techniques for RP include Stereolithography (SLA), Fused Deposition Modeling (FDM), and 3D Printing (3DP). SLA uses a

¹ Assistant Professor, Engineering Studies Program, Armstrong Atlantic State University, 11935 Abercorn St., Savannah, GA 31419, wayne.johnson@armstrong.edu

² Associate Professor, Engineering Studies Program, Armstrong Atlantic State University, 11935 Abercorn St., Savannah, GA 31419, cameron.coates@armstrong.edu

³ Undergraduate Student, Engineering Studies Program, Armstrong Atlantic State University, 11935 Abercorn St., Savannah, GA 31419

⁴ Undergraduate Student, Department of Engineering Technology, Savannah State University, 3219 College Street, Savannah, Georgia 31404

photosensitive liquid polymer which hardens when exposed to a laser beam. FDM extrudes a heated plastic filament through a nozzle to create the layers of a part. Three dimensional printing is a powder based technique in which the powder is solidified with the application of adhesives via an inkjet head. All techniques fabricate the physical model by building up the part one layer at a time as the build platform moves up or down (depending on the specific technique). Commercially available entry-level machines used to fabricate physical models cost between \$20,000 and \$50,000. This relatively high cost has been a barrier for adopting this technology at smaller engineering programs.

This paper will present our progress towards incorporating RP technology in the engineering graphics course at Armstrong Atlantic State University. Our objectives are four-fold: 1) To promote student awareness of this burgeoning technology as a tool in design visualization; 2) To improve student spatial visualization skills with the use of rapid prototyped (physical) models; 3) To provide students with practical experience in part measurement and CAD solid model generation with the use of rapid prototyped models; and 4) To expose students to the rapid prototyping fabrication process using the relatively inexpensive Fab@Home desktop rapid prototyping system. All of the equipment used for this project was purchased using small institutional grant funds and assembled by the undergraduate engineering student co-authors. The following sections will provide a discussion of the engineering graphics course, and descriptions of the modules developed to introduce and utilize rapid prototyping technology in the course.

ENGINEERING GRAPHICS COURSE

The engineering graphics course (ENGR 1170) is taught every fall and spring semester at Armstrong Atlantic State University (AASU). The course is part of the curriculum for the Georgia Tech Regional Engineering Program (GTREP) in which students complete their first two years at AASU, Savannah State University, or Georgia Southern University and then transfer to the Georgia Tech Savannah campus to complete their engineering degree. Enrollment in ENGR 1170 is typically 10-16 students. The course consists of three lecture hours and 2.75 lab hours per week. Some of the key objectives of the course include: 1) Visualization of objects and ideas; 2) Sketching pictorials and multiviews of objects; 3) Creation of 2D and 3D CAD models; 4) Generation and interpretation of schematics; and 5) Participation in a team engineering activity.

ENGR 1170 course and lab exercises used to achieve objectives 1 and 2 have consisted of generating multiview drawings based on provided isometric pictorials of objects and vice-versa. Implicit in this activity is the students' spatial visualization capacity--that is, their ability to cognitively visualize the shapes and orientation of objects from various viewpoints. Spatial visualization has received much attention in the literature [1, 3, 7] and has been linked to student's problem solving skills [8], their capacity to learn and use 3D solid modeling packages [9], and their overall success in engineering and science careers [10]. Typically about 40% of the enrolled students have had difficulties with these course exercises.

Another aspect of the course is a final project in which student teams create a complete set of working drawings using a 3D solid modeling package (SolidWorks). Student teams are required to select a device or system to dissect, measure and develop 3D CAD models of the device. For most students, this is their first time working with a physical part to develop a CAD model based on their own measurements using digital calipers. The practice of generating 3D solid models based directly on part measurement is also an activity performed by engineers in industry (e.g., reverse engineering of legacy equipment).

As previously mentioned, rapid prototyping has been given more emphasis in engineering textbooks and used in a variety of engineering education scenarios. It is vital that students are made aware (provided knowledge) of these advances in technology, to clearly apply (application) and observe (evaluation) them in practice. Four course/lab modules have been developed to achieve the stated objectives of this paper and will now be discussed in more detail.

MODULE 1: DEVELOPMENT OF 3-D SOLID MODELS USING RAPID PROTOTYPED MODELS

In this module students are given an RP model and digital calipers and requested to create a 3D solid model of the part using SolidWorks. One of the RP models used for this module is shown in Figure 1. A total of 75 RP models (used in Modules 1 and 3, with model's cost/volume approximately \$17/in³) and 14 digital calipers were purchased with funds from an internal AASU teaching and learning grant of \$2452. Figure 2 shows a student measuring one of the parts used in the module in order to create a corresponding 3D CAD model.

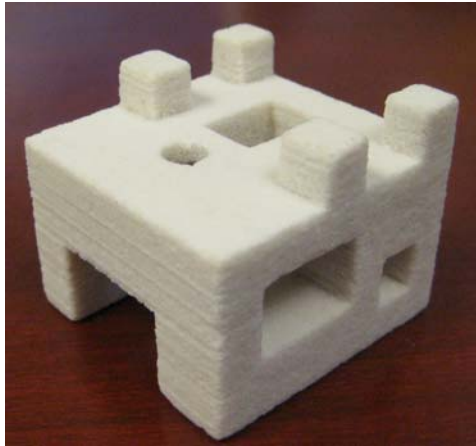

Figure 1. Rapid prototyped (3DP) model created by a 3rd party rapid prototyping services bureau for Module 1.



Figure 2. Student measuring a part with digital calipers during Module 1 in the ENGR 1170 lab.

The CAD models used in Modules 1 and 3 were originally created in SolidWorks and submitted to a rapid prototyping service bureau for fabrication. The parts were constructed using starch infused with wax to provide added strength. The turn-around time to receive the parts was two weeks.

MODULE 2: CLASS LECTURE ON RAPID PROTOTYPING

Module 2 presents a general overview of the main rapid prototyping techniques in use in academia and industry. The lecture also highlights additional applications for RP beyond what is presented in their textbook including medical and architectural applications. This lecture is given after Module 1 with the intention of capitalizing on the students' piqued interest in RP based on their hands-on application and use of the RP models in Module 1.

MODULE 3: GENERATION OF MULTIVIEW DRAWINGS ASSISTED WITH RAPID PROTOTYPED MODELS

In this module, students are first given a dimensioned isometric drawing of a part (see Figure 3) and required to generate a multiview drawing of the part. Their work is photocopied and returned to them along with a physical (RP) model of the same part. The students are then allowed to modify their original work based on comparisons with the physical model. An example of a student's modification and the associated RP model is shown in Figure 4. The circled features depict the specific changes made by the student.

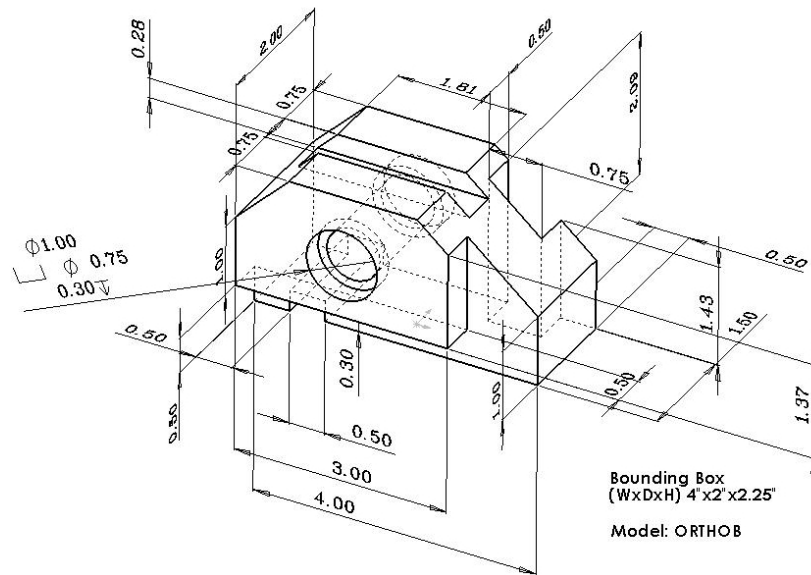

Figure 3. Trimetric view of model used to generate multiview drawing. Note: Location of counterbored holes has been omitted for clarity.

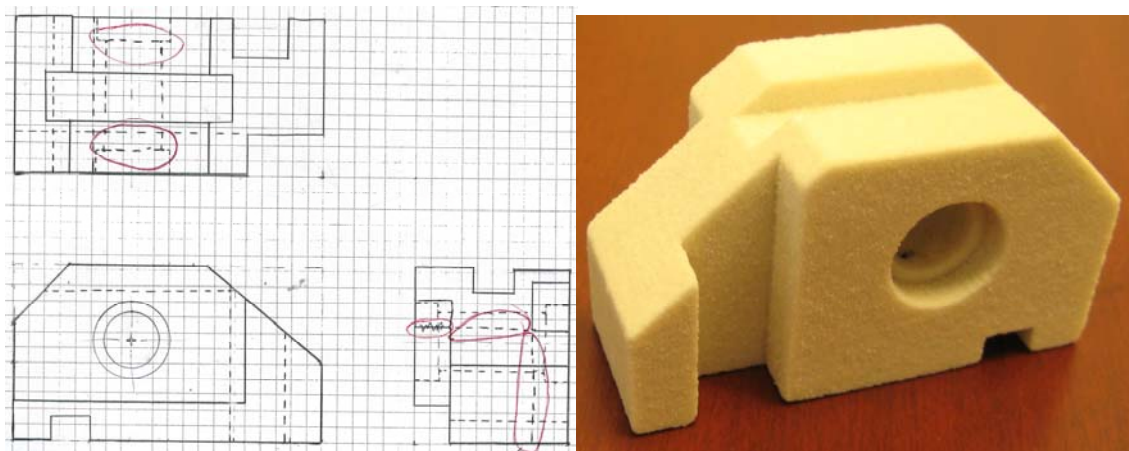

Figure 4. Student's modified multiview drawing (left) based on input from the RP model (right).

MODULE 4: FAB@AASU -DESKTOP RAPID PROTOTYPING

This module is based on the desktop rapid prototyping Fab@Home kit [11]. It was originally developed at Cornell University as an affordable and open source alternative to the more expensive commercially available rapid prototyping systems. The kit was purchased for \$3000 from a Savannah State University (SSU) undergraduate research program sponsored by the National Science Foundation. The program pairs an SSU undergraduate student with a faculty mentor on a summer research project. The kit was assembled in 60 hours with initial testing of the system still ongoing. Figure 5 shows the assembled kit. The device incorporates a microcontroller positioning system driven by three linear stepper motors and a material deposition system, all enclosed in an acrylic housing structure. The positioning system allows for three axes of control for the deposition system, with a fourth axis to control the amount of material deposition. The material deposition system consists of a linear stepper motor with a non-captive lead screw mounted above a 10cc disposable syringe barrel. The lead screw extends into the syringe barrel to extrude the build material. The control system interfaces with a PC via USB and the Fab@Home software program to interpret the STL file (see Figure 5). Several rudimentary parts have been fabricated using off-the-shelf silicone (see Figure 6).

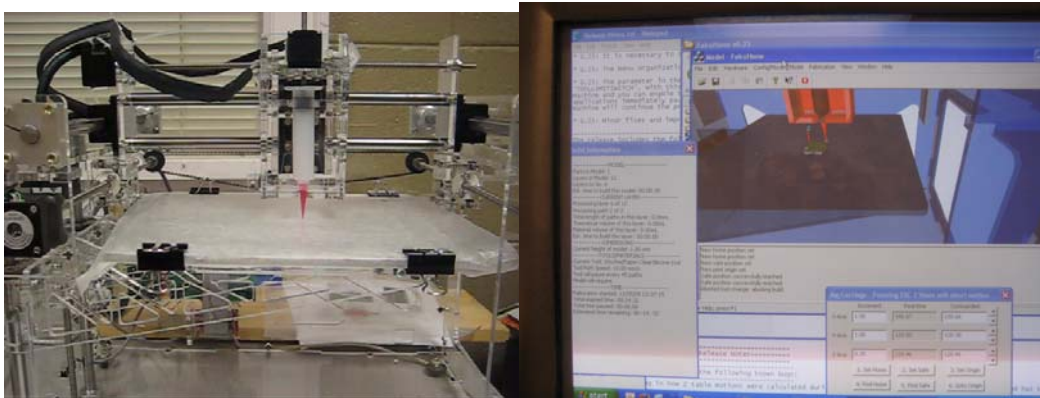

Figure 5. Assembled Fab@Home kit and PC based application software used to interface with kit.



Figure 6. Examples of fabricated parts using the Fab@Home kit

The fabricated parts in Figure 6 have been displayed during the lecture on rapid prototyping (Module 2). Work is currently in progress to improve the consistency of the build quality of parts before the kit can be fully utilized in our engineering graphics course (e.g., allowing unsupervised student access to the device). Once this is completed, the kit will be used for in-lab demonstrations of the fabrication process and projects in the engineering graphics course.

DISCUSSION

The results of Module 1 were very positive. All of the 11 students enrolled in the engineering graphics course successfully created the 3D CAD model using the RP model and digital calipers. The results from Module 3 were not as successful as Module 1. All 11 students initially had one or more errors in their completed multiviews of the part shown in Figure 3, and only four students made changes to their drawings once given the corresponding RP model. Of these four students, two reduced the number of errors by 50% and two reduced the number of errors by 100% (no errors). Our small sample size notwithstanding, it is thought that students may not have been fully motivated to thoroughly re-examine their drawings since the exercise was only graded on effort. More data will be collected with a standard grading protocol in future iterations of this exercise.

The qualitative results of the project consisted of an examination of student comments from the Faculty and Course Evaluations (FACE). The following are some of the student comments:

"...rapid prototyping was really helpful."

"I liked the rapid prototyping section...it would be better if we had a (RP) machine to play with"

"rapid prototyping was extremely helpful"

"rapid prototyping was a great example of what the programs we are learning are capable of doing"

"RP was very helpful in comparing our drawings with the actual object"

"(RP) helped us with visualization"

There were no negative comments about RP from the students. The clear sentiments of the student comments were that RP was helpful in visualization and it presented a real-world application of the course materials taught in the course. It is interesting to note that while they perceived that the RP models helped them to visualize the parts, it was not strongly reflected in their performance of Module 3.

CONCLUSIONS

We have presented our experiences in employing rapid prototyping in the engineering graphics course at Armstrong Atlantic State University. Although the cost of commercially available RP machines may be out of reach for smaller engineering programs, it is still possible to obtain RP parts via rapid prototyping service bureaus for about \$17 per cubic inch. These parts can be used for various lab exercises to generate 3D CAD models using actual measurements of physical models. They can also be used to aid students in spatial visualization of parts. Student feedback on the use of RP models in the engineering graphics course was very positive. Work will continue on setting up the Fab@Home kit as it has significant potential in making RP technology more accessible to engineering students.

ACKNOWLEDGEMENTS

The first author would like to acknowledge funding from the Armstrong Atlantic State University Office of Sponsored Programs and the NSF/Savannah State University MAGEC-STEM program. He is also grateful for the assistance of William Cantrell (AASU undergraduate student) is helping to troubleshoot and build additional models using the Fab@Home kit.

REFERENCES

- [1] Bertoline, W., and E.N. Wiebbe, *Fundamentals of Graphics Communication* 5ed., New York: McGraw Hill, 2006.
- [2] Lieu, D.K., and S. Sorby, *Visualization, Modeling, And Graphics For Engineering Design*, 1 ed., Clifton Park: Delmar/Thompson, 2009.
- [3] Sorby, S., A.F. Wysocki, and B.J. Baartmans, *Introduction to 3D Spatial Visualization: An Active Approach* Clifton Park: Delmar Learning/Thomson, 2003.
- [4] Barr, R.E., P.S. Schmidt, T.J. Krueger, and C. Twu, "An Introduction to Engineering Through an Integrated Reverse Engineering and Design Graphics Project", *Journal of Engineering Education* Vol. 89, No. 4, 2000, pp. 413-418.
- [5] Jensen, D., C. Randall, J. Feland, and M. Bowe, "A Study of Rapid Prototyping for Use in Undergraduate Design Education", *American Society for Engineering Education*, Montreal, Quebec, Canada: ASEE, 2002.
- [6] Rodriguez, J., A. Choudhury, M. Keil, S. Ramrattan, and P. Ikonov, "Application of rapid prototyping for engineering design projects", *American Society for Engineering Education Annual Conference and Exposition*, Chicago, IL: ASEE, 2006.
- [7] Hartman, N., P. Connolly, J. Gilger, and G. Bertoline, "Developing a Virtual Reality-Based Spatial Visualization Assessment Instrument", *American Society for Engineering Education Annual Conference and Exposition*, Chicago, IL: ASEE, 2006.
- [8] Koch, D.S., "The Effects of Solid Modeling and Visualization On Technical Problem Solving", *School of Education*, Blacksburg: Virginia Polytechnic Institute and State University, 2006.
- [9] Hamlin, A., N. Boersma, and S.A. Sorby, "Do Spatial Abilities Impact the Learning of 3-D Solid Modeling Software", *American Society for Engineering Education Annual Conference and Exposition*, Chicago, IL: ASEE, 2006.
- [10] Sorby, S.A., "Developing 3D spatial skills for engineering students", *Australasian Journal of Engineering Education* Vol. 13, No. 1, 2007.
- [11] Malone, E., "Fab@Home". <http://www.fabathome.org>. Accessed 18 November 2008.

Wayne M. Johnson

Wayne M. Johnson is an Assistant Professor of Engineering Studies at Armstrong Atlantic State University, Savannah GA. He received his Ph.D. in mechanical engineering from the Georgia Institute of Technology in 2004. His current research interests are engineering education, vibrations, and mechatronics.

Cameron W. Coates

Cameron W. Coates is an Associate Professor of Engineering Studies at Armstrong Atlantic State University, Savannah GA. He received his Ph.D. in aerospace engineering from the Georgia Institute of Technology in 2001. His current research interests are structural mechanics, structural health monitoring and biomechanics of bone tissues.

Patrick Hager

Patrick Hager is a civil engineering undergraduate student. He is currently completing his degree in civil engineering at the Georgia Tech Savannah campus.

Nyrell Stevens

Nyrell Stevens is a mechanical engineering undergraduate student. He is currently in his sophomore year at Savannah State University.